

257030000

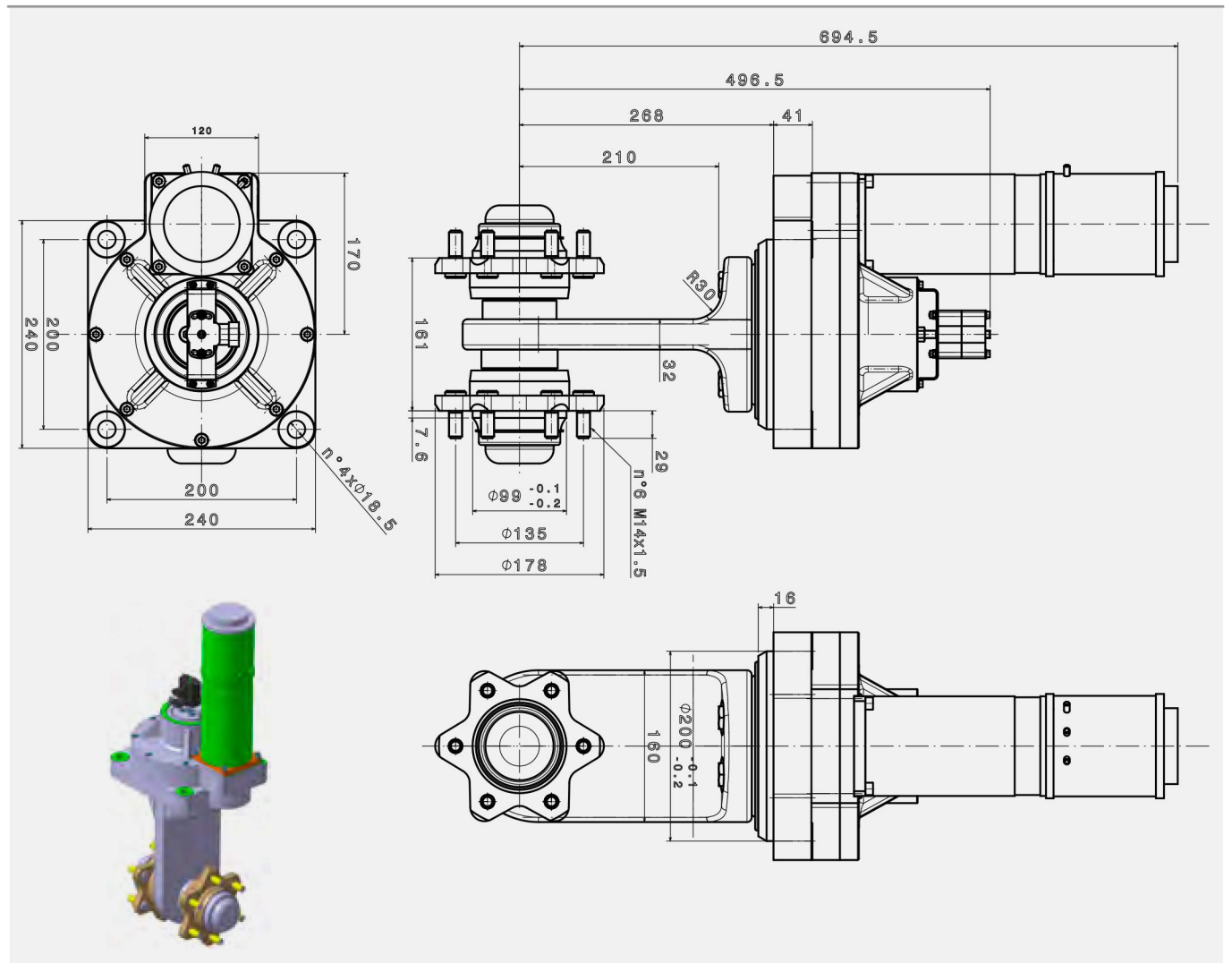

MAX LOAD ON THE AXLE (Kg)

1600

2300

APPLICATION



TECHNICAL SPECIFICATIONS

MAX LOAD ON THE AXLE	1600 Kg - 2300 Kg
MAX DYNAMIC LOAD ON EACH WHEEL	400W 48V AC
ALLOWABLE TIRE SIZE	Superelastic 16x6-8
STEERING FEEDBACK	Mechanical or magnetic rotary potentiometer
ELECTRIC STEERING MOTOR	400W 24-48V AC

* The centering of the wheel hub, and the diameter of the threaded hole or stud can be made at the request