

599050000

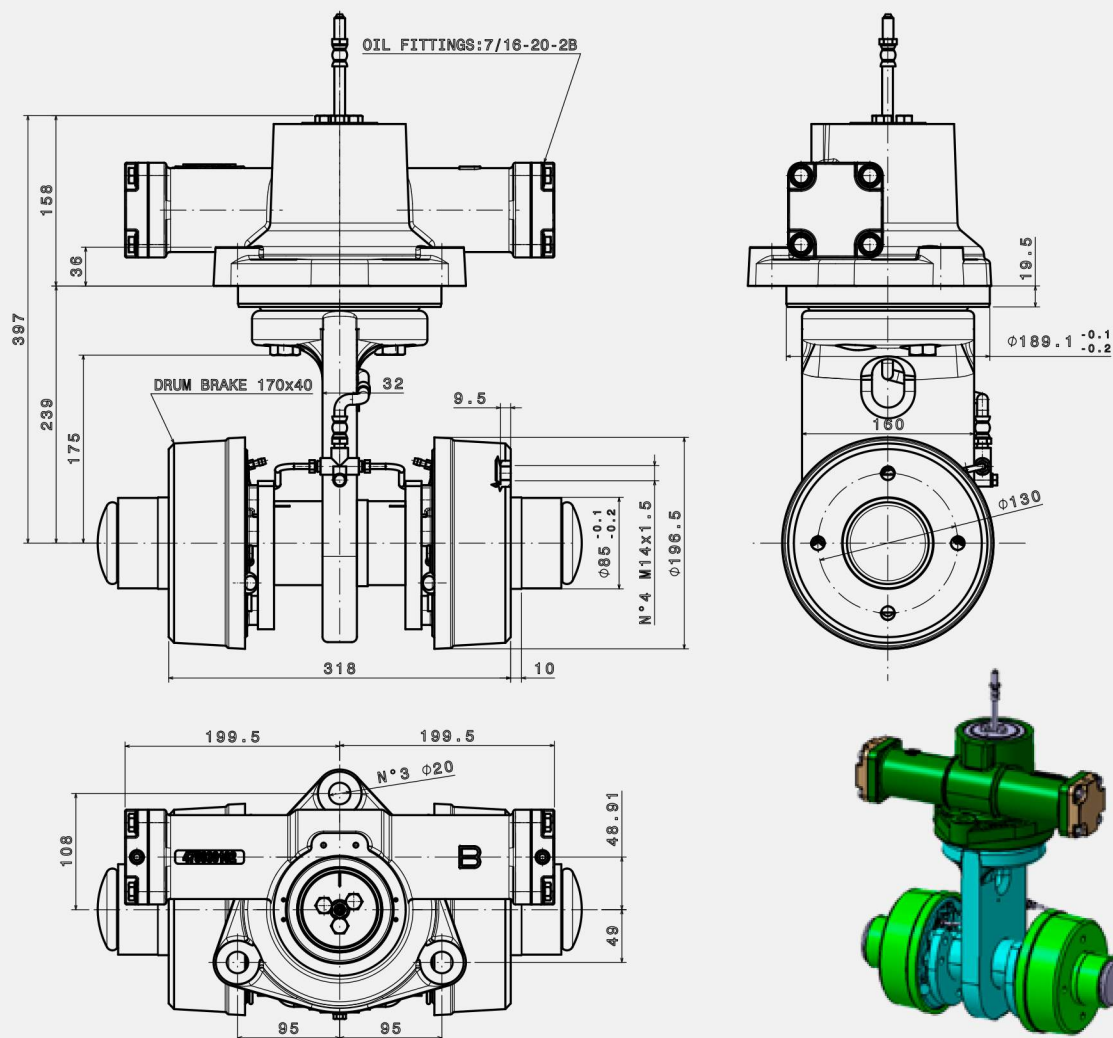

STATIC LOAD (Kg)



APPLICATION

TECHNICAL SPECIFICATIONS

WEIGHT	80 KG
STATIC LOAD	1000 KG
OIL VOLUME FOR TOTAL STEERING	266,8 CM ³
MAX ANGLE STEERING	85° - 90°

* The centering of the wheel hub, and the diameter of the threaded hole or stud can be made at the request