

TBe800

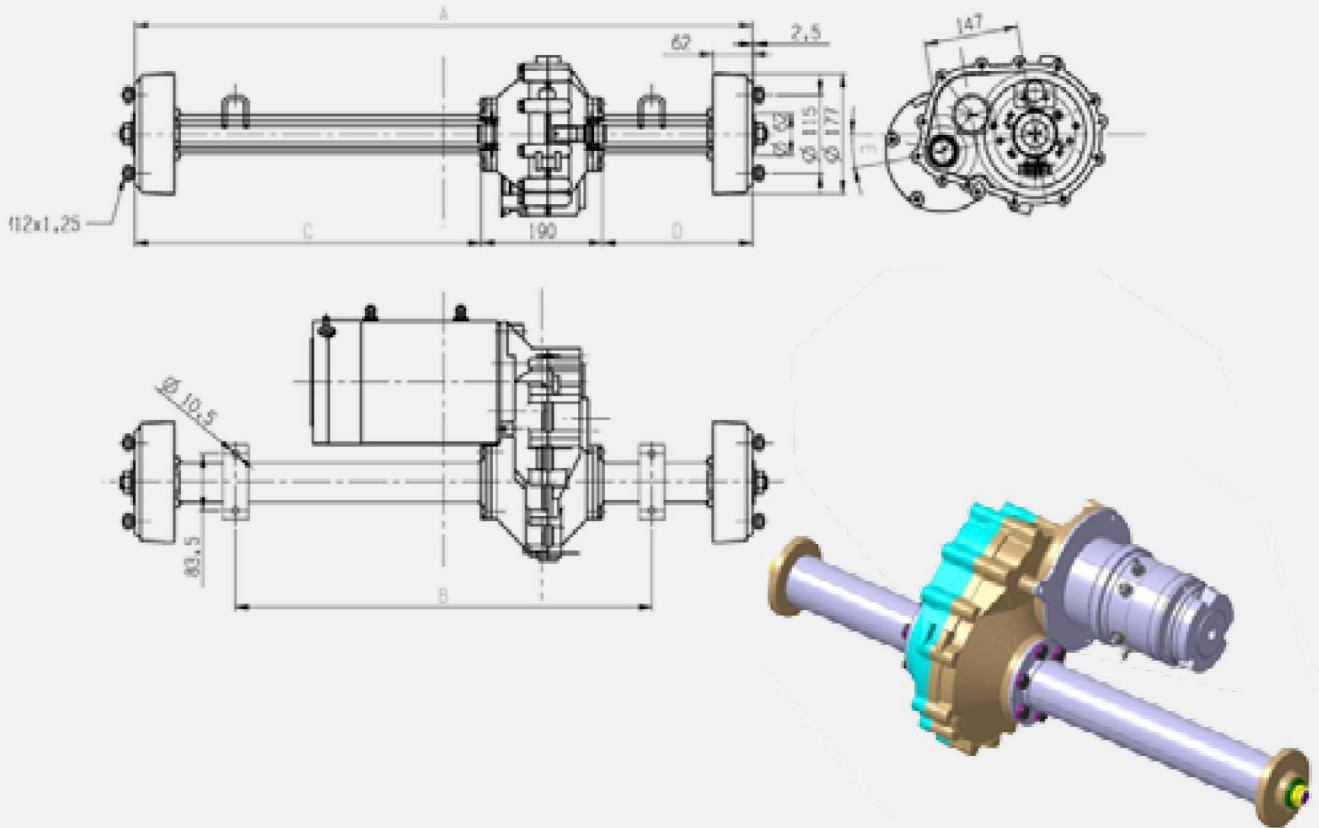

MAX OUTPUT PEAK TORQUE AT THE WHEEL (Nm)
MAXIMUM LOAD CAPACITY (Kg)

800

APPLICATION



TECHNICAL SPECIFICATIONS

MAXIMUM TRACTION MOTOR RATED POWER	5.0 kW (*)
AVAILABLE SUPPLY	24V DC MP o SEM, 24V o 48V AC
AVAILABLE TRACTION MOTORS	700W 24V DC MP, 1200W 24V DC SEM
MAX OUTPUT PEAK TORQUE AT THE WHEEL	800 Nm
MAX OUTPUT CONTINUOUS TORQUE AT THE WHEEL	600 Nm
MAX RPM IN INPUT	7.000 rpm
AVAILABLE RATIOS	1:15, 1:27
MAX LOAD ON THE AXLE (**)	800 kg
HYDRAULIC SERVICE DRUM BRAKE	Ø160x35
MAX SERVICE BRAKE TORQUE	570Nm a 140 bar each wheel
ELECTROMAGNETIC PARKING BRAKE	5Nm, 10Nm, 20Nm

(*) electric traction motors are sized with a S2=60 min duty cycle

(**) Our axles are sized with an adequate safety factor