

ELECTRIC STEERING

EBv400

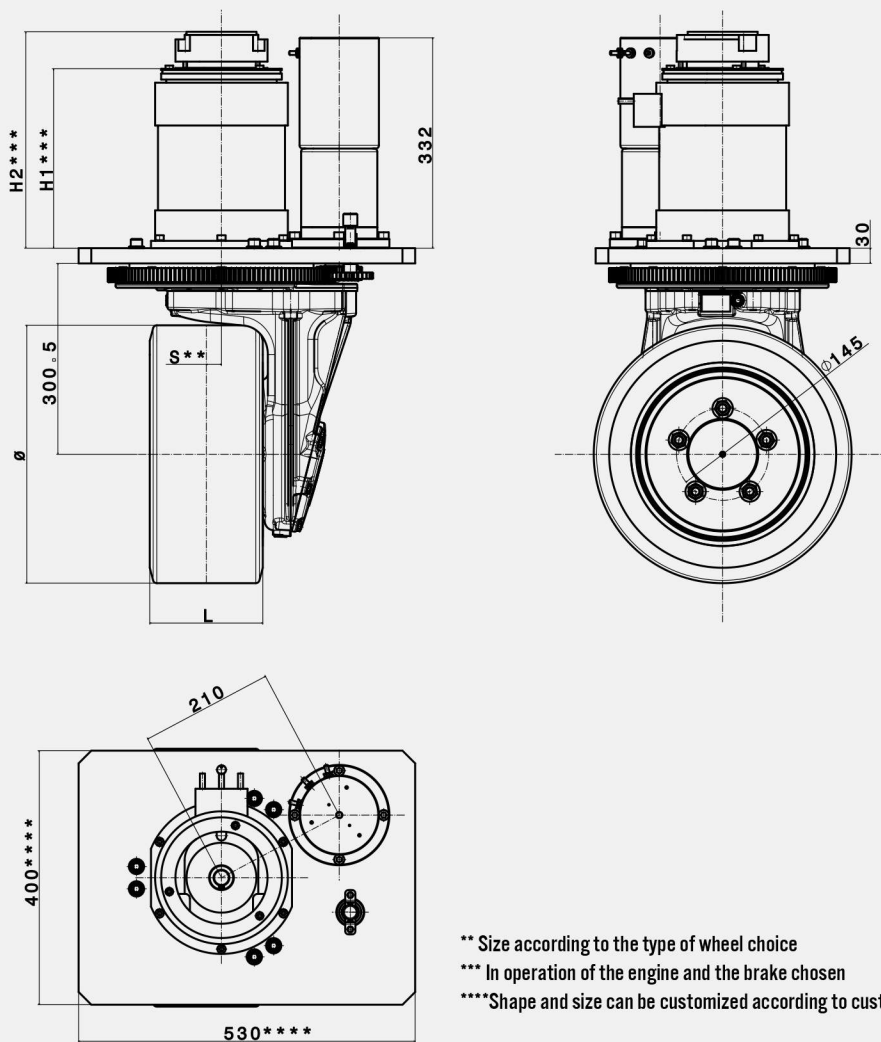

** Size according to the type of wheel choice
 *** In operation of the engine and the brake chosen
 **** Shape and size can be customized according to customer specifications

APPLICATION

MAXIMUM LOAD CAPACITY (Kg)



TECHNICAL SPECIFICATIONS

MAXIMUM LOAD CAPACITY	3400 kg	WHEEL DIMENSION (ØxL)*	405x130 mm
REDUCTION RATIO	19/22/25	POWER OF STEERING MOTOR	600 W
MAXIMUM POWER TRACTION MOTOR	6000 W	STEERING MOTOR POWER SUPPLY (AC)	24/48/80 V
SUPPLY VOLTAGE (AC)	24/48/80 V	STEERING FEEDBACK	Rotary potentiometer /Steering sensor
PEACK TORQUE AT THE WHEEL	1400 Nm	PARKING E/M BRAKE	40/75 Nm
CONTINUOUS TORQUE AT THE WHEEL	453 Nm	AVAILABLE TYRES	black rubber / polyurethane/ vulkolan/supertrack / superelastic

* Other types of materials and wheel at the customer's request