

EBo 1450

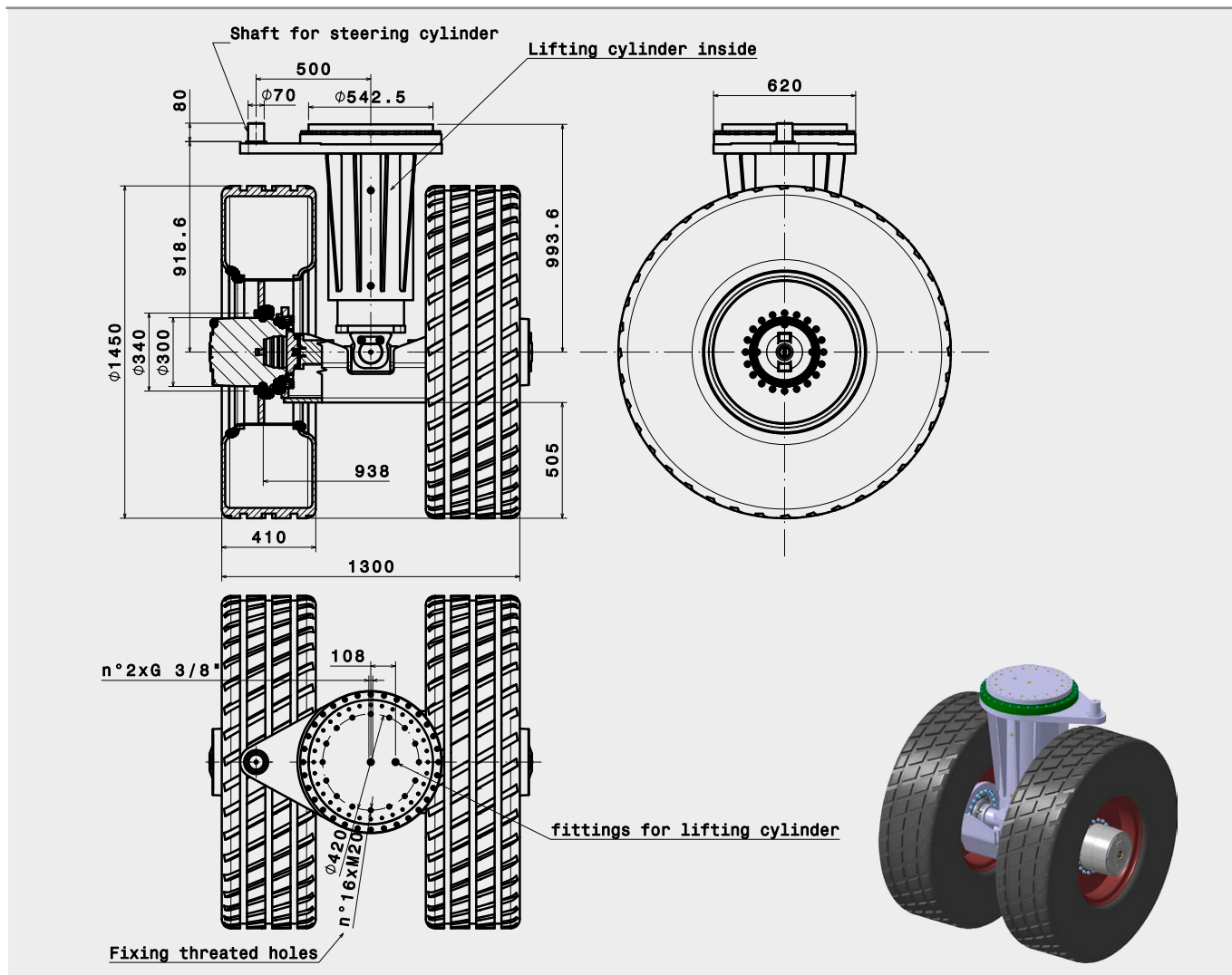

APPLICATION

MAX LOAD ON THE WHEEL (KG)

30.000



TECHNICAL SPECIFICATIONS

MAX LOAD ON THE GROUP	30.000 kg	MOTOR DISPLACEMENT	125 cc/rev
RIMS AND TIRES	Pneumatic 16.00 - 25	INTERNAL LIFTING CYLINDER	$\phi 160 \times \phi 90$
MAX SPEED	2 km/h	TOTAL LIFTING STROKE	150 mm (± 75)
REDUCTION RATIO	1:63	LIFTING PRESSURE PAYLOAD	149 BAR
HYDRAULIC MOTOR	N°2 SAUER DANFOSS OMSS125		